

Generation 2022 single wallbox Pedestal single/double

Installation manual

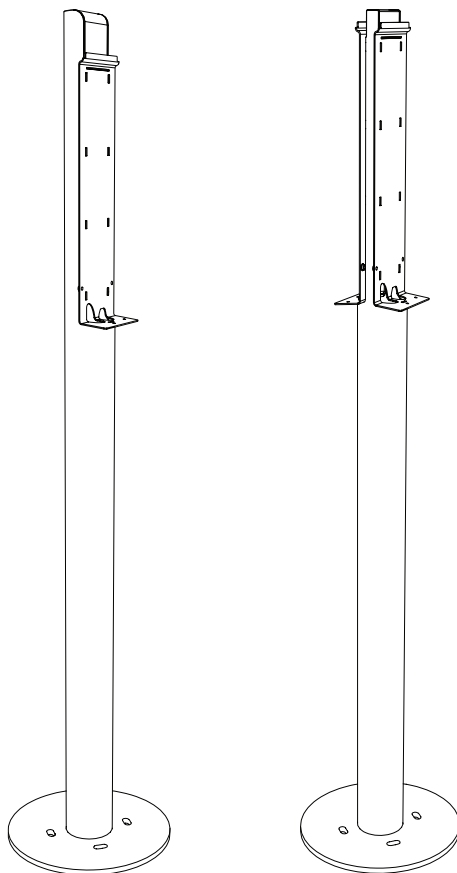



To access the Single Wallbox Installation Manual
please scan the QR code



To access the Pedestal Installation manual
please scan the QR code



To access the Single Wallbox User Manual
please scan the QR code

CONTENTS

Required tools.....	4
Pedestal installation.....	5
Anchor attachment	6
Pedestal mounting	8

REQUIRED TOOLS

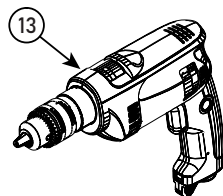
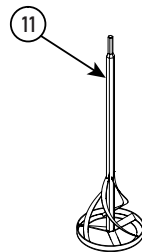
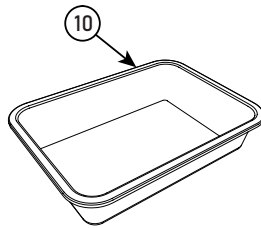
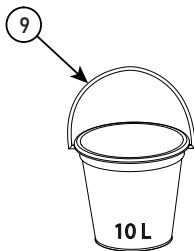
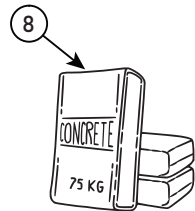
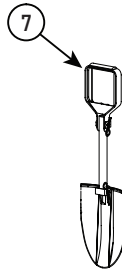
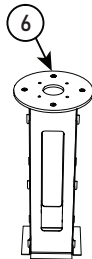
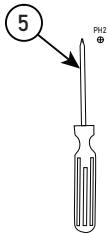
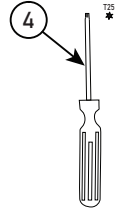
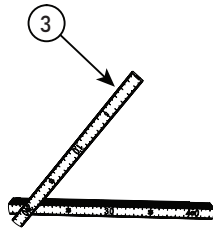
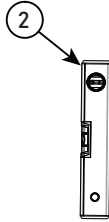
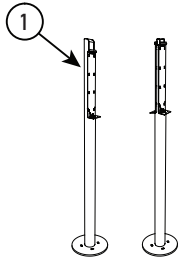

#	Description	Amount
1	eNovates pedestal	x1
2	Spirit level	x1
3	Folding rule	x1
4	Screwdriver Torx T25	x1
5	Screwdriver PH2	x1
	<i>Only required when installing on soft soil:</i>	
6	Anchor	x1
7	Spade	x1
8	Concrete	75 kg
9	Bucket of water	10 liter
10	Large mixing tub	x1
11	Mixer	x1
12	Hammer drill	x1
13	Drill 10 mm	x1

PEDESTAL INSTALLATION

The base of the pedestal can be fixed to an anchor that is buried in the ground.

Carefully consider where the charging station will be created, and how the charger unit(s) will need to be oriented. The anchor will be set into the ground and the pedestal will be set on the anchor, aligned with the holes in the anchor pole. Keep this in mind when considering the desired final orientation of the charger unit(s).

Make sure that the power cord and Ethernet cable are already available (two of each cable when a double pedestal is used) and that the cables will be able to reach up through the pedestal from below, at the position where the pedestal will be placed. For more details, refer to the main installation manual for your product.

Anchor attachment

1. Dig a hole for the ground anchor, approximately 50 cm deep and 30 x 40 cm wide.

Caution: there may be objects in the ground which you want to avoid hitting. Check for the presence of underground objects before you start digging.

Note: avoid digging much deeper than necessary, as this will cause the soil to become looser. In a few years' time, the stability of the ground mount may degrade if the soil is too loose.

2. Make sure the necessary underground cables lead into the created hole and stick out from it. They must be able to reach up into the charger unit and to be connected to the charger unit when the anchor and pedestal are placed.
3. Assemble the anchor.

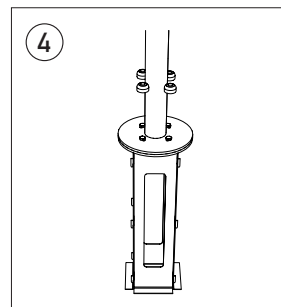
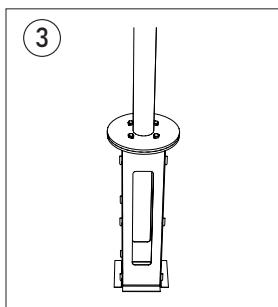
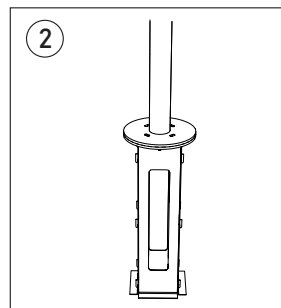
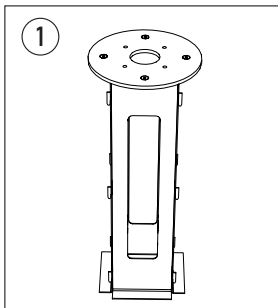

-
4. Lead the cables through the anchor's central axis until they stick out, and place the anchor in the hole. Make sure the anchor is level and that the pedestal can be attached to the pole slot at surface level.
 5. Make sure the pedestal bracket is facing the way you want it to. When properly positioned, fix the pedestal to the anchor slot with 3 screws.
 6. Pour concrete to fix the anchor in place. Let the concrete harden. If necessary, add a layer of filler soil on top of the hardened concrete and stomp the soil down until it is level.
 7. Feed the cables from the anchor through the inside of the pedestal and out of the opening at the bottom of the pedestal bracket. Then place the pedestal onto the anchor's pole slot.

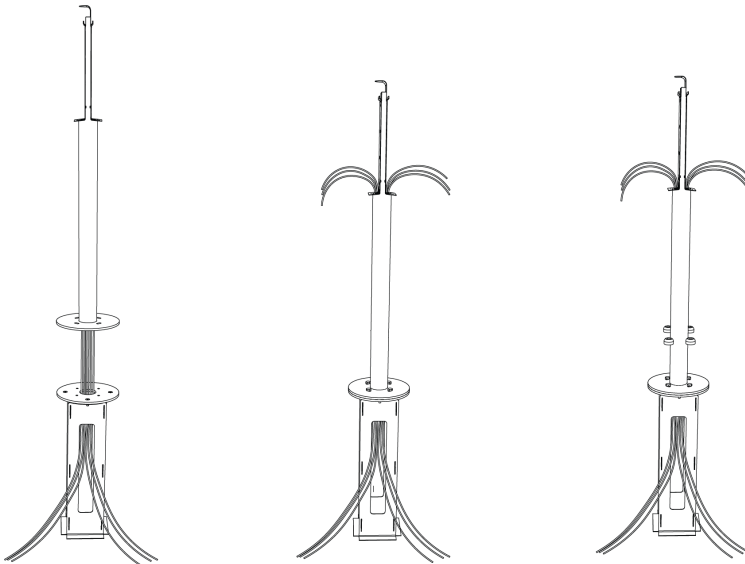

PEDESTAL MOUNTING

The mounting procedure consists of a few steps:

1. Secure the cable block to the pedestal.
2. Slide the charger onto the pedestal.
3. Secure the charger to the pedestal.
4. Connect the cables.
5. Attach and secure the cover.
6. Attach and secure the socket lid.
7. If necessary, attach a CE sticker.

Secure the cable block to the pedestal.

1. Slot the cable block onto the bottom of the pedestal bracket. Orient the cable block so that the cables can pass from the circular holes in the bottom corner of the pedestal bracket through the cable block and into the charger unit, when the charger unit is attached.

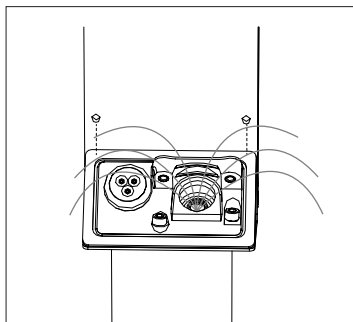
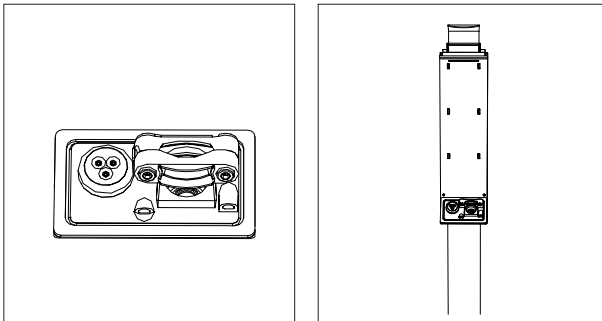

-
2. Use the provided 2 M5x16 screws (Torque 1.2Nm) to secure the cable block onto the bottom of the pedestal bracket.

Please refer to the step “Slide the charger onto the wall bracket” in the Wall Mounting chapter of the product manual to perform the following steps in the mounting procedure. The same principles that apply to the wall bracket in the product manual from this step forward, can be applied to the pedestal bracket.

Notes

Manufacturer:

Enovates N.V. • Brandstraat 13 • 9160 Lokeren • Belgium
KBO 0833.089.547